

受控文件

直流无刷无齿槽电机规格书
SLOTLESS BRUSHLESS DC MOTOR SPECIFICATIONS

鸣志电器(太仓)有限公司

规格 Specifications		Values	Tolerance	Unit
1. 电机参数 Motor parameters				
1.1	轴承类型 Bearings type of motor	Ball bearing		
1.2	电机极数 Number of poles	2		
1.3	相数 Number of phases	3		
1.4	绝缘等级 Insulation class	F (155°C)		
1.5	相间电阻 Terminal resistance phase to phase	48.1	±8%	Ω
1.6	相间电感 Terminal inductance phase to phase	1220	Typical	μH
1.7	速度常数 Speed constant	624	±10%	rpm/V
1.8	转矩常数 Torque constant	15.3	Typical	mNm/A
1.9	速度/转矩斜率 Speed/torque gradient	1961	Typical	rpm/mNm



2. 齿轮箱参数 Gearhead data		Values	Tolerance	Unit
2.1	齿轮箱类型 Type of gearhead	Planetary gearhead		
2.2	轴承类型 Bearings type of gearhead	Ball bearing		
2.3	名义减速比 Nominal reduction ratio	406	Nominal	X:1
2.4	精确减速比 Absolute reduction ratio	27843750/68590		
2.5	级数 Number of stages	4		
2.6	平均空载回差 Average backlash no load	1.5	Typical	°
2.7	旋转方向 Rotation direction(input/output)	=		
2.8	轴向间隙 Axial play	0~0.1		mm
2.9	径向间隙 Radial play[mm from flange]	≤0.1[5]		mm
2.10	最大轴向负载 Max.axial load(dynamic)	20		N
2.11	最大径向负载 Max.radial load[mm from flange]	50[5]		N
2.12	最大允许安装力 Max.force for press fits	40		N

规格 Specifications		Values	Tolerance	Unit
3. 整机常规特性 Overall General Data				
3.1	额定电压 Nominal voltage	24		V dc
3.2	空载转速 No load speed	37	±10%	rpm
3.3	空载电流 No load current	34	±50%	mA
3.4	额定转矩 Rated torque	650	Typical	mNm
3.5	额定电流 Rated current	0.164	±10%	A
3.6	额定转速 Rated speed	21.6	±10%	rpm
3.7	最大效率 Maximun efficiency	47	Typical	%
3.8	堵转转矩 Stall torque	2.34	Typical	Nm
3.9	堵转电流 Stall current	0.5	Typical	A
3.10	重量 Weight	73	±5%	g
3.11	使用温度范围 Ambient temperature	-40~+85		°C

4. 其他 Others				
4.1				
4.2				
4.3				
4.4				

备注 Notes:

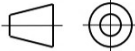
- 所有参数均在20°C给定。大部分参数随温度变化。
All parameters are given at 20°C. Most of parameters will vary with temperature.
- 当电机固定在导热支架上时，热阻通常可降低50%。
The thermal resistance can be typically decreased of 50% when motor is fixed on a thermally conductive support.
- 电机电气安全标准符合<GB/T 21418中6.6介电性能>的要求。
The electrical safety standard of the motor shall meet the requirements of <GB/T21418 6.6 Dielectric properties>.

			Unit:mm 第一角画法 First angle method 	批准 Approve			 <p>This document is released for information only. Its reproduction in whole or in part or its dissemination to third parties is prohibited. All trademarks and registered trademarks appearing on this document are the property of their respective owners.</p>
			未注线性与角度尺寸公差 Tolerances for linear and angular dimensions without individual tolerance indications GB/T 1804-m eqv ISO 2768-1:m	标准化 Standardize			
			未注形状与位置尺寸公差 Geometrical tolerance for features without individual tolerance indications GB/T 1184-K eqv ISO 2768-2:K	工艺 Process Review			
A1	EC:24-290 修改3处	2024.02.28		审核 Check			
A0	原始版本 Original revision	2022.08.04		设计 Design			
REV.	版本记录 REVISION RECORD	DATE	UNLESS OTHERWISE SPECIFIED	NAMES	SIGNATURE	DATE	Drawing No: 4611180000531 Rev. A1 SCALE: 1:1 Sheet 1 of 3

受控文件

鸣志电器(太仓)有限公司

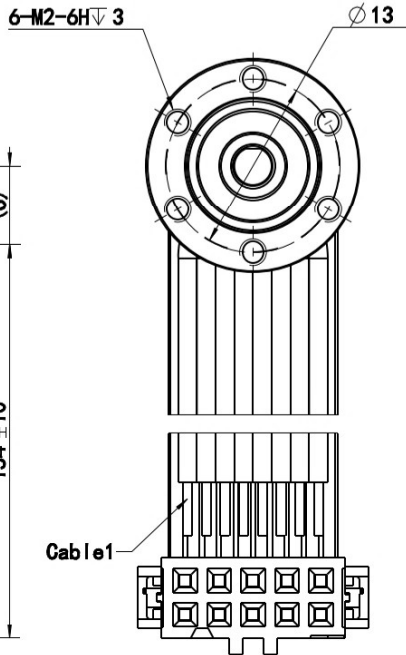
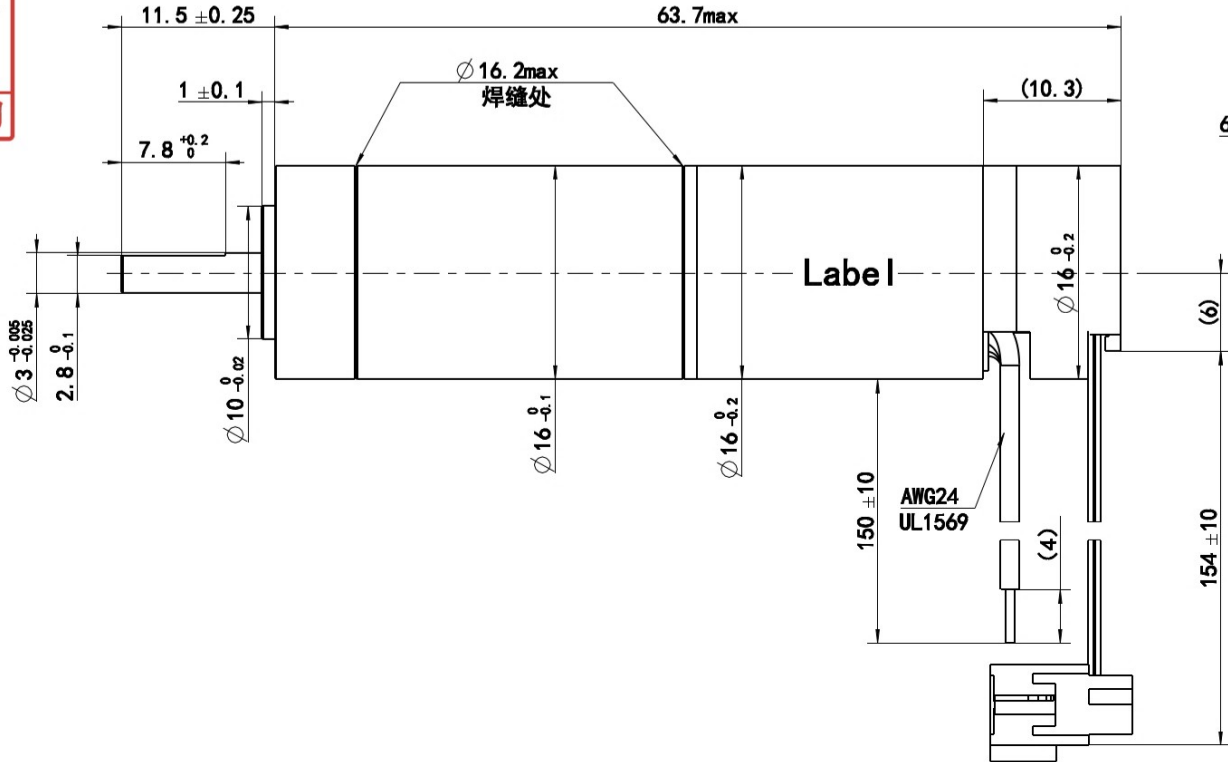
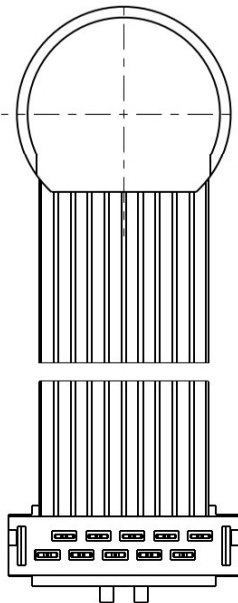

线束相对于前盖安装孔角度偏差: ≤±30°
Alignment of cable relative to front mounting holes: ≤±30°

Connection of Motor

Cable No.	信号/Signal	颜色/Color
1	U	棕/brown
2	V	红/red
3	W	橙/orange
4	V _{hall} 3~24 VDC	黄/yellow
5	GND	绿/green
6	Hall 1	蓝/blue
7	Hall 2	紫/voilet
8	Hall 3	灰/grey

铭牌 Label Detail

MOONS'
 Motor No. ECU16024H24-S108
 Encoder No. M16-1024
 Gearbox No. PG16M-0406
 Work order XXXXXXXXXX YYYY
 Serial No. QR Code

备注/Note:
 1. 铭牌用激光标刻在电机机壳表面, 目视水平居中;
 The label is laser engraved on the motor housing in middle.
 2. 二维码为含整机型号、生产工单号和序列号。
 The QR code includes motor model No., work order and serial No.

			Unit:mm 第一角画法 First angle method	批准 Approve					
			未注线性与角度尺寸公差 Tolerances for linear and angular dimensions without individual tolerance indications GB/T 1804-m eqv ISO 2768-1:m	标准化 Standardize					
			未注形状与位置尺寸公差 Geometrical tolerance for features without individual tolerance indications GB/T 1184-K eqv ISO 2768-2:K	工艺 Process Review					
A1	EC:24-290 修改3处	2024.02.28		审核 Check					
A0	原始版本 Original revision	2022.08.04		设计 Design					
REV.	版本记录 REVISION RECORD	DATE	UNLESS OTHERWISE SPECIFIED	NAMES	SIGNATURE	DATE	Drawing No: 4611180000531	Rev. A1	SCALE: 2.5:1 Sheet 2 of 3



This document is released for information only. Its reproduction in whole or in part or its dissemination to third parties is prohibited. All trademarks and registered trademarks appearing on this document are the property of their respective owners.

受 控 文 件

鸣志电器(太仓)有限公司

编码器信息 Encoder Informations

编码器参数 Encoder Parameter		
1	工作原理类型 Working principle	Magnetic
2	信号记录类别 Signal record type	Incremental
3	每圈线数 Lines per turn	1024
4	通道数量 Number of channels	3

Connection of Encoder

Pin No.	信号/Signal
1	N. C
2	VCC 4.5V-5.5V
3	GND
4	N. C
5	Channel \bar{A}
6	Channel A
7	Channel \bar{B}
8	Channel B
9	Channel \bar{I}
10	Channel I

编码器输出信号/Encoder Output Signal

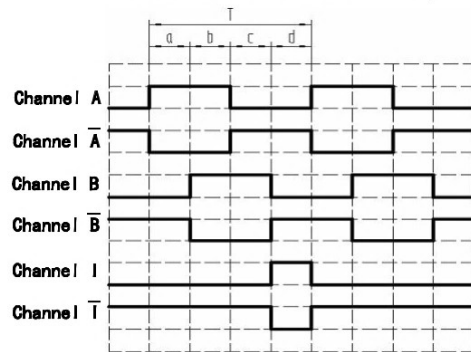

Direction of rotation: CW (view from shaft end);
 a, b, c, d=90°±45°;
 Index is aligned with angle commutation zero

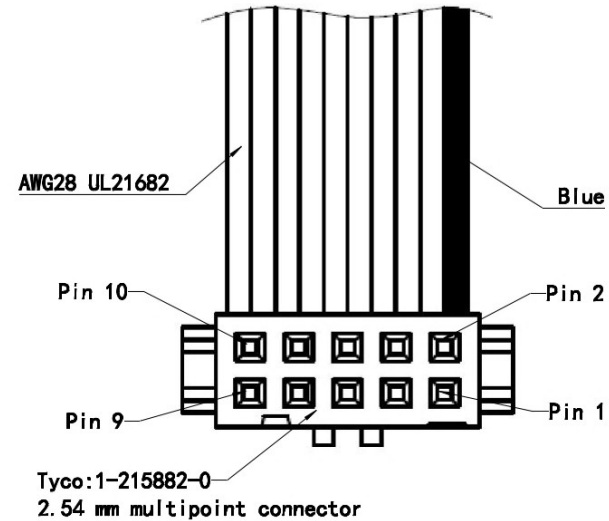

备注 Notes:

- 连接器引脚1和4不可施加电压，否则会损坏编码器；
The encoder will be damaged if applying voltage to pin1& pin4 of the connector.
- 不允许以编码器线束着力来提起电机。
It is not allowed to lift the motor with the encoder cable.

			Unit:mm 第一角画法 First angle method	批准 Approve			
			未注线性与角度尺寸公差 Tolerances for linear and angular dimensions without individual tolerance indications GB/T 1804-m eqv ISO 2768-1:m	标准化 Standardize			
			未注形状与位置尺寸公差 Geometrical tolerance for features without individual tolerance indications GB/T 1184-K eqv ISO 2768-2:K	工艺 Process Review			
A1	EC:24-290 修改3处	2024.02.28		审核 Check			
A0	原始版本 Original revision	2022.08.04		设计 Design			
REV.	版本记录 REVISION RECORD	DATE	UNLESS OTHERWISE SPECIFIED	NAMES	SIGNATURE	DATE	This document is released for information only. Its reproduction in whole or in part or its dissemination to third parties is prohibited. All trademarks and registered trademarks appearing on this document are the property of their respective owners.
1	2	3	4	5	6	7	Drawing No: 4611180000531 Rev. A1 SCALE: 1:1 Sheet 3 of 3